

APPLICATIONS BULLETIN

Fitting a new 4-20mA two wire transducer.

Connection details

To use this input note the wiring requirements on the PCB. A 24VDC power supply is available on board for 2-wire configuration
Typical 4-20mA application shown.

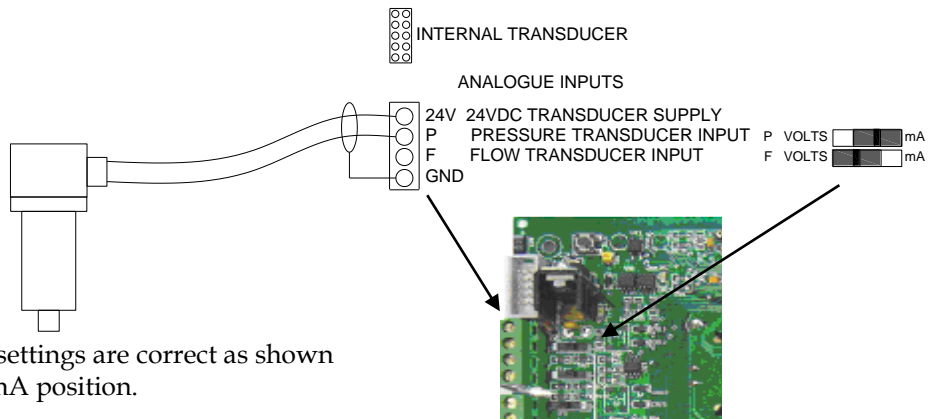

Note: Make sure the switch settings are correct as shown in the picture – Both in the mA position.

To confirm connection is correct.

Select “Analogue Input 1” in the Pump Data Log menu

If the connection is correct the display will read approximately 20% without any pressure applied to the transducer.
If the display show less than 2% reverse the connections to the transducer.

Analogue Input 1
XXX.XX%

Transducer Zero

The Transducer Zero adjusts the zero offset in the pressure sensor. This display can be found in the configuration menu.
Remove pressure in the system and disconnect the pressure tube.

Transducer Zero
XXXX

Automatic Zero.

Press ENTER (*) to begin editing the ZERO PRESSURE; then press and hold both UP and DOWN buttons together for 1 second or until “Finding Zero” is displayed on the screen.

In 5-20 seconds zero will be displayed; press ENTER (*) to finish the operation.
(This feature is not available on versions prior to 4310)

Manual Zero (Primary Transducer)

Press ENTER (*) and then the DOWN key to decrease the displayed value to ZERO. If “Value Too Low” appears, increase the value slowly by pressing the UP key until a zero value is obtained. *NOTE* The value does not change with each press of the UP/DOWN key. Press and hold the UP/DOWN key for rapid change and single press for small change. The reading will not change by one number for each key press.

When ZERO is displayed press ENTER (*) to finish the operation.

Reconnect pressure tube before re-enabling pumps.

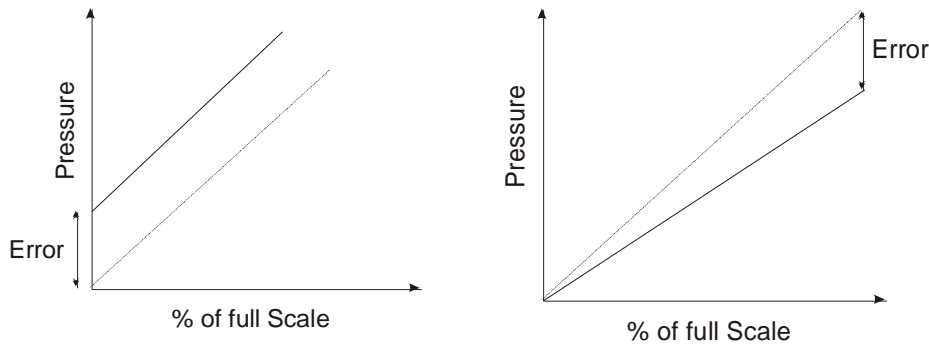

Adjust Pressure (Primary Transducer)

The calibration of the analogue sensors is achieved by adjusting the pressure reading on this screen to match a reading from a pressure gauge. This will only need to be done if a new or non-standard Techsys transducer is fitted. This display can also be found in the configuration menu

**Adjust Pressure
XXXX**

Pressurise the system, when it has stabilised press the ENTER key, then press either the UP or DOWN keys to adjust the reading on this screen to match the pressure gauge reading. The display data will not change by one number for each key press, holding down a key will increment the data at a quicker rate. Once the readings are matched the system pressure is calibrated. Press ENTER again and then exit the menu to store the data.

Transition to the new reading may take some time to settle, wait for 5 seconds before accepting the adjustment.

Installation complete.

